

Digital Camera Workshop

PowerShot G5
DIGITAL CAMERA

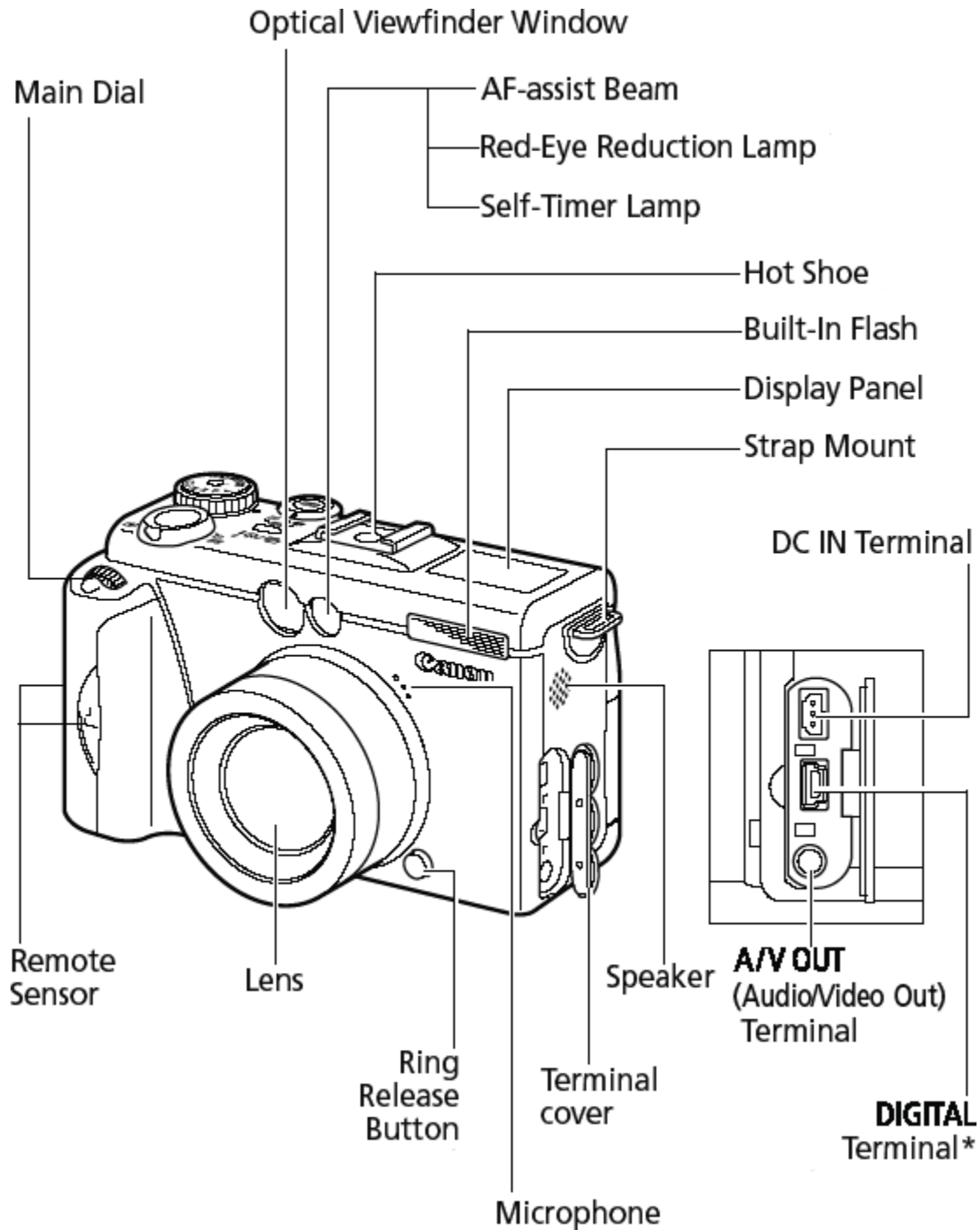

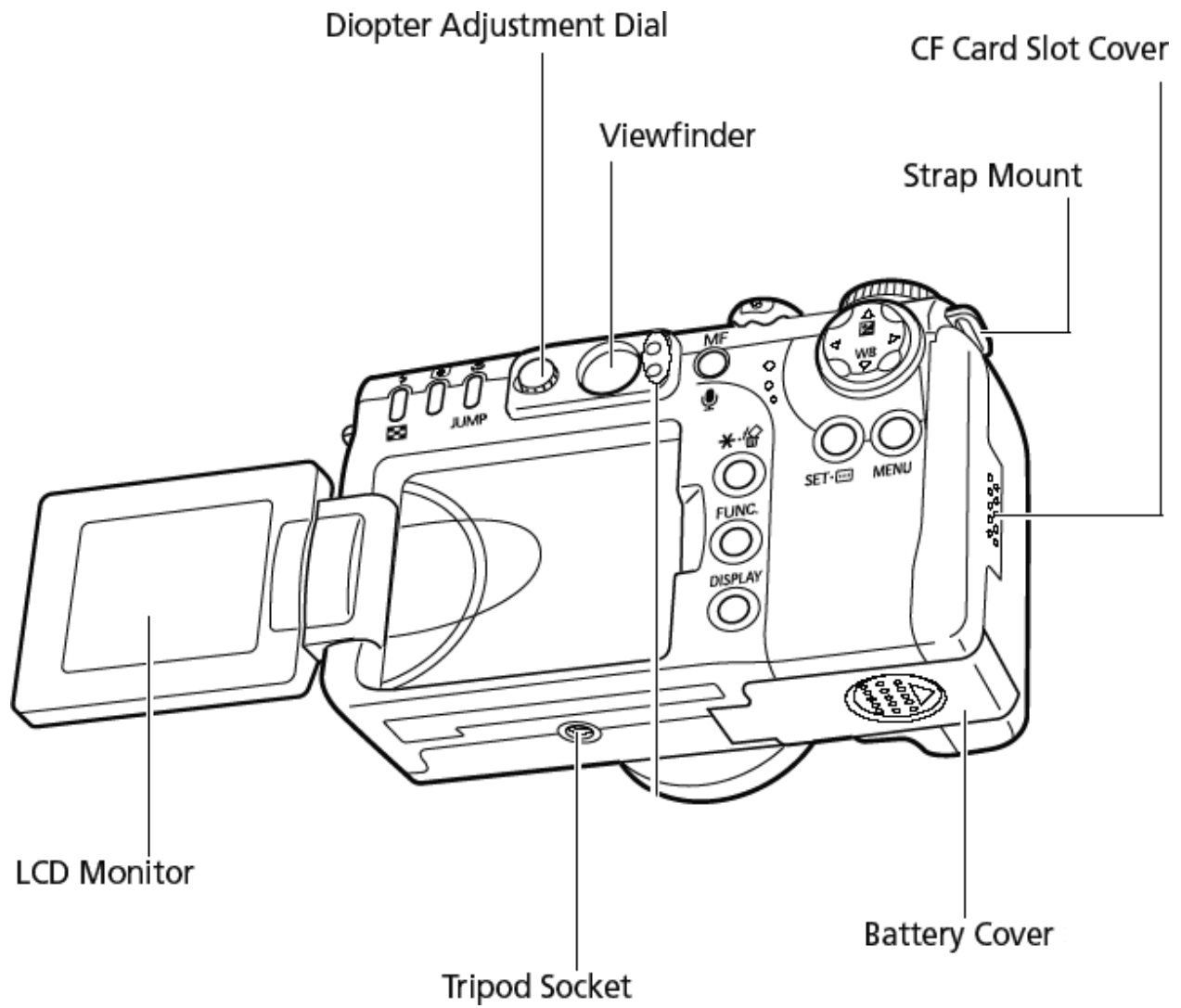

Top

Center for Teaching and Learning

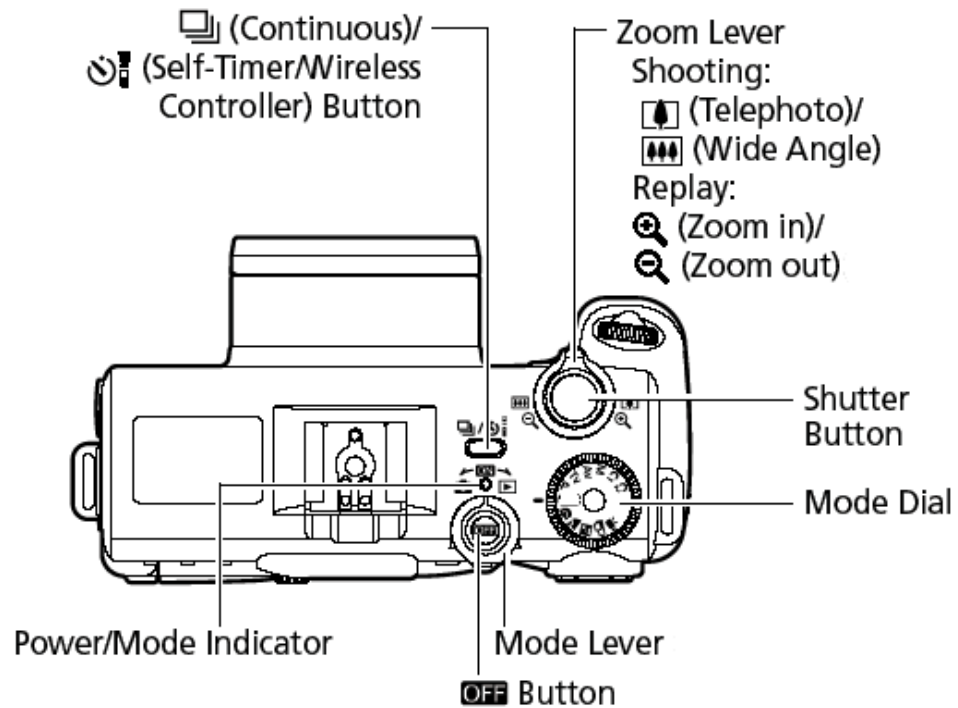

Back

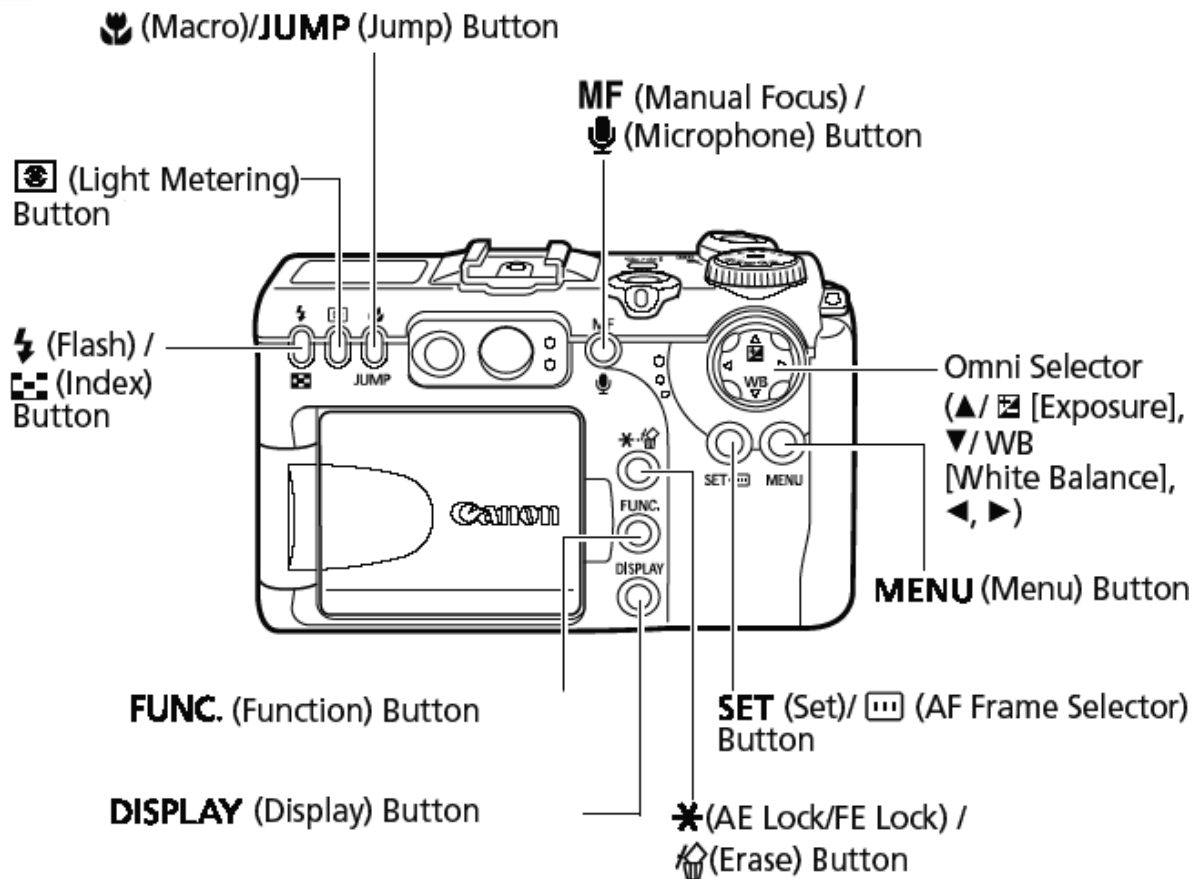

STEP 1: Preparing the Camera

A. Installing the battery pack:

- 1** Turn off the camera (p. 29).
Check that the power/mode indicator is not lit.
-

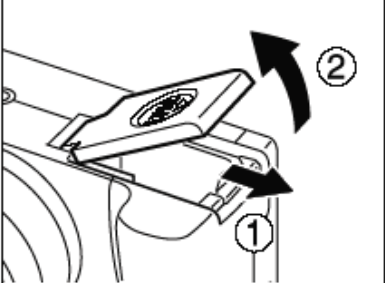
- 2**  Slide the battery cover in the direction of the arrows.
-

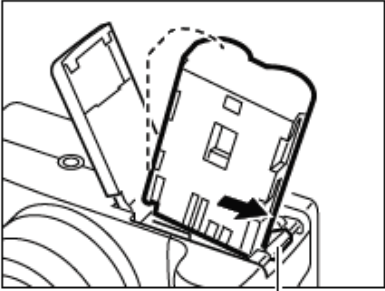
- 3**  Press the battery lock while inserting the battery pack all the way in until the lock clicks.
To remove the battery pack, release the battery lock.
- Battery lock
-

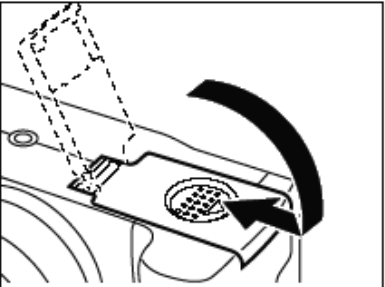
- 4**  Slide the battery cover closed.

B. Charge the battery pack:

- 1** Turn off the power
Make sure that the power/mode indicator is off.
-

- 2** Slide the battery cover in the direction of the arrows.

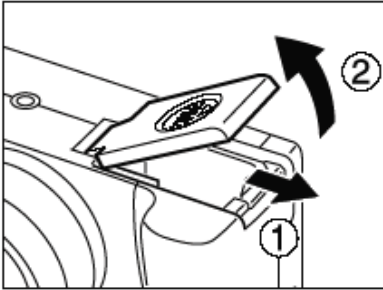

- 3** Press the battery lock while inserting the Battery Pack BP-511 and close the battery cover.

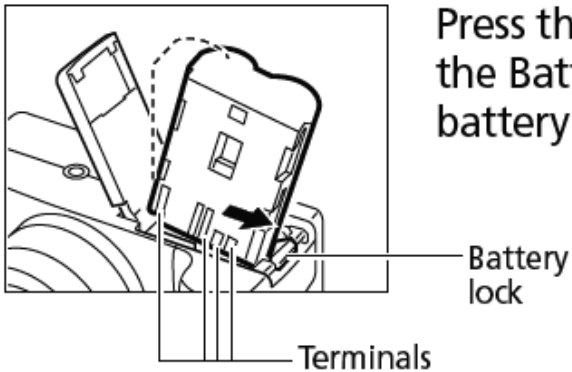

- 4** Attach the power cord to the compact power adapter and plug it into power outlet.

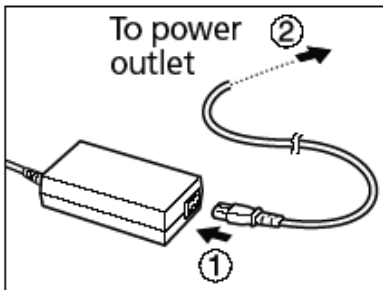

5

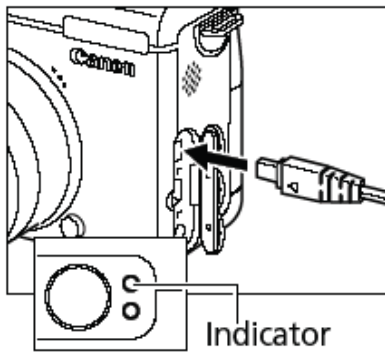

Connect the DC plug of the compact power adapter to the camera's DC IN terminal.

- The indicator beside the viewfinder will blink orange while the battery pack is charging and change to steady orange when it is approximately 90% charged, which is adequate for use. If it is charged for approximately 2 more hours, it will become fully charged and the indicator will switch to green.
- After charging the battery, remove it from the camera when the camera will not be used.

C. Installing a CF card:

1

Turn off the camera

Check that the power/mode indicator is not lit.

2

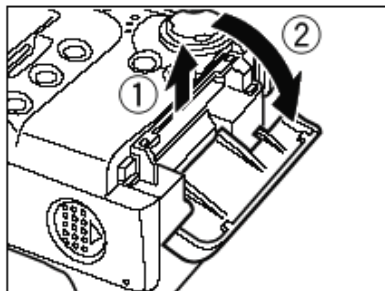

Slide the CF card slot cover in the direction of the arrow and lift it open.

3

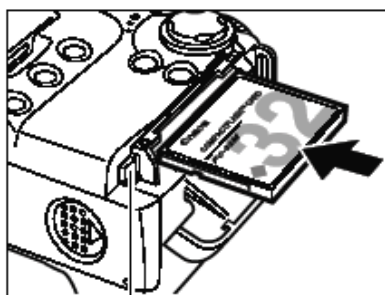

CF Card Eject Button

Insert the CF card with the label facing up.

- Push the card in until the CF card eject button fully extends.
- To remove the CF card, push the CF card eject button and pull the card out.

STEP 2: Shooting

A. Turning the Power On/Off

The power/mode indicator remains lit while the power of the camera is on. The power/mode indicator indicates the state of the camera as follows.

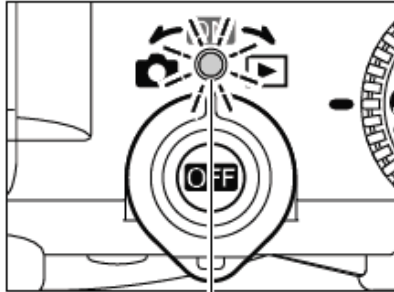

Power/Mode Indicator

Orange: Shooting mode

Green: Replaying mode/Printer connection mode*

Yellow: Computer connection mode*

Off: The power of the camera is off.

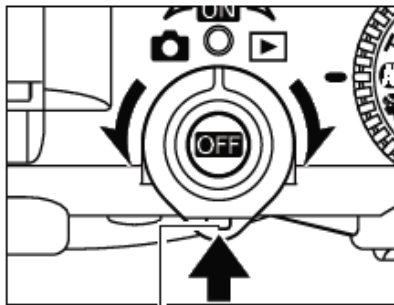

Release button

Mode Lever

Use this lever to turn the power on. To operate the mode lever, press the release button as shown at left. The mode lever will not operate if release button is not pressed.

After the camera is turned on, release the lever. The mode lever returns to its original position (center).

B. Powering the camera in Shooting Mode

1

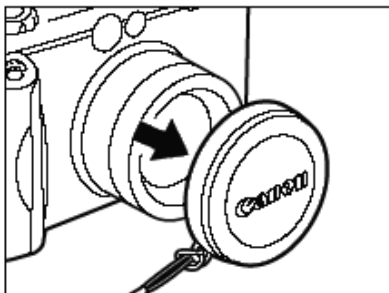

Remove the lens cap.

2

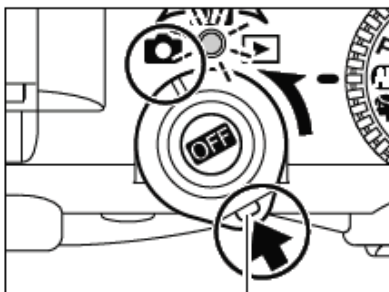

Release button

Turn the mode lever to  (Shooting) while pressing the release button.

- The power/mode indicator lights orange.
- Open the LCD monitor if needed

C. Using the Zoom

The zoom can be adjusted from 35 to 140 mm (equivalent to 35 mm film format).

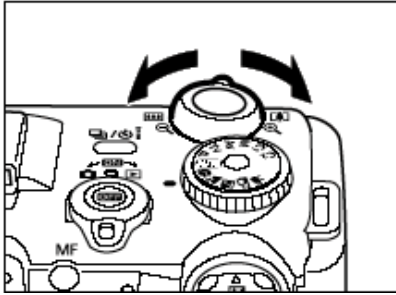

Telephoto / Wide Angle

- Press the zoom lever toward to zoom in (telephoto).
- Press the zoom lever toward to zoom out (wide angle).

D. Auto Mode

1 Check that the camera is in Shooting mode

2 Turn the mode dial to **AUTO**.

3 Aim the camera at the subject.

4 Use the zoom lever to achieve the desired composition (relative subject size in the viewfinder).

5 Press the shutter button halfway

- Two beeps will sound when the camera has finished metering, and the indicator beside the viewfinder will light green or orange. If the LCD monitor is on, the AF frame will appear green.
- The shutter speed and aperture value are automatically determined and show on the display panel. They also show on the LCD monitor if it is on.
- The yellow indicator will blink and the beep will sound one time if the subject is difficult to focus on. The AF frame will also appear yellow.

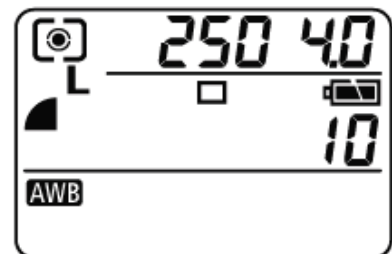

AF Frame

6 Press the shutter button all the way

- You will hear the sound of the shutter when the shutter activates.
- The picture appears for two seconds on the LCD monitor, if it is on.

STEP 3: Powering the camera in Replay Mode

1

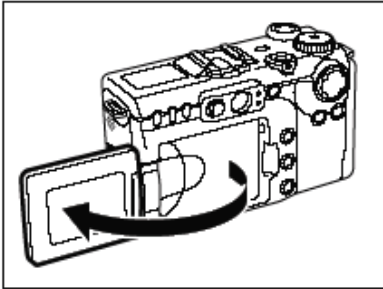

Open the LCD monitor.

The LCD monitor can be freely opened to any position

2

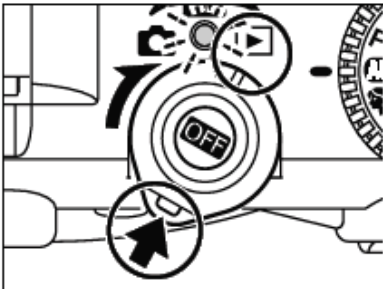

Turn the mode lever to .

- The last recorded image appears (single image replay).
- **Pb** appears on the display panel.

3

Move between images turning the main dial or using the ◀ or ▶ arrow on the omni selector.

- Use ◀ to move to the previous image and ▶ to move to the next. Holding ◀ or ▶ moves more rapidly between images, but the images will not appear as clearly.
- Turn the main dial to the left to move to the previous image and to the right to move to the next.
- Turn the main dial or press the ◀ or ▶ arrow on the omni controller after having pressed the **JUMP** button, to jump 10 images behind or ahead. If you press the **JUMP** button once more, the camera returns to the single image replay screen.



STEP 4: Erasing Images Individually

 Please note that erased images cannot be recovered. Exercise caution before erasing a file.

1 Set the camera to the replay mode

2 Select the image you wish to erase by turning the main dial or by using the ◀ or ▶ arrow on the omni selector and press the  button.

3 Select [Erase] using the ◀ or ▶ arrow on the omni selector and press the **SET** button.

To cancel instead of erasing, select [Cancel] and press the **SET** button.



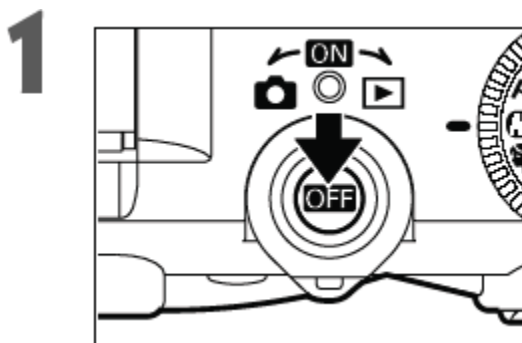

STEP 5: Turning the Power Off

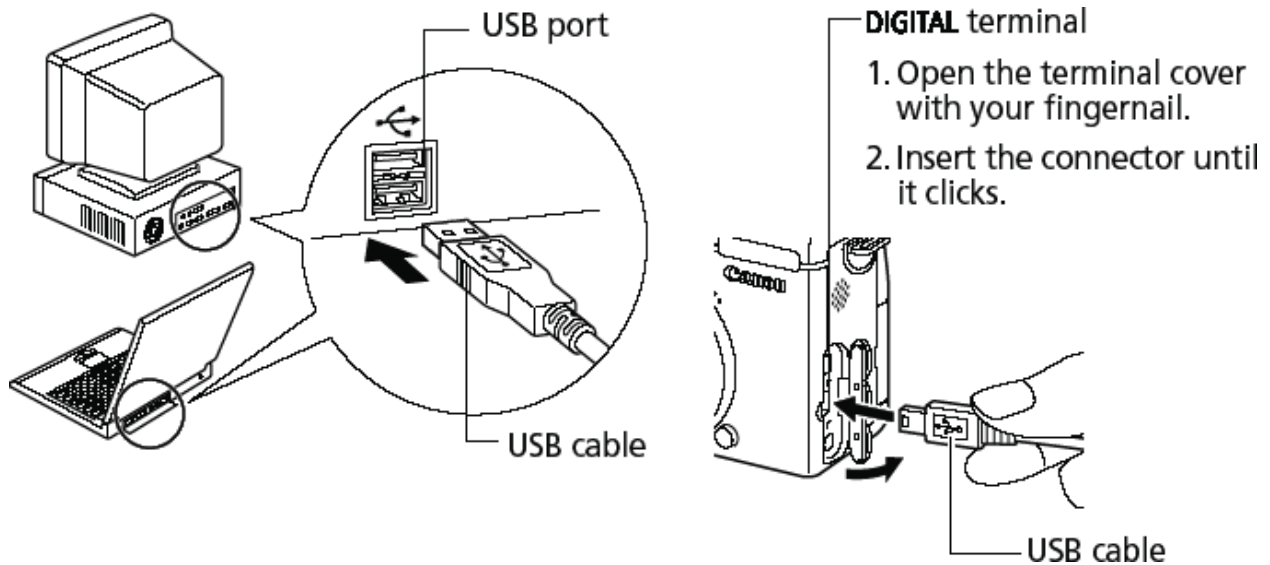

Press the **OFF** button.
The power goes off.

STEP 6: Downloading Images to a computer



1. Connect the camera to the computer using the USB cable.
2. Set the camera's mode switch to  and turn on the power.
3. Windows XP operating system will automatically detect the camera and install the necessary drivers for it.

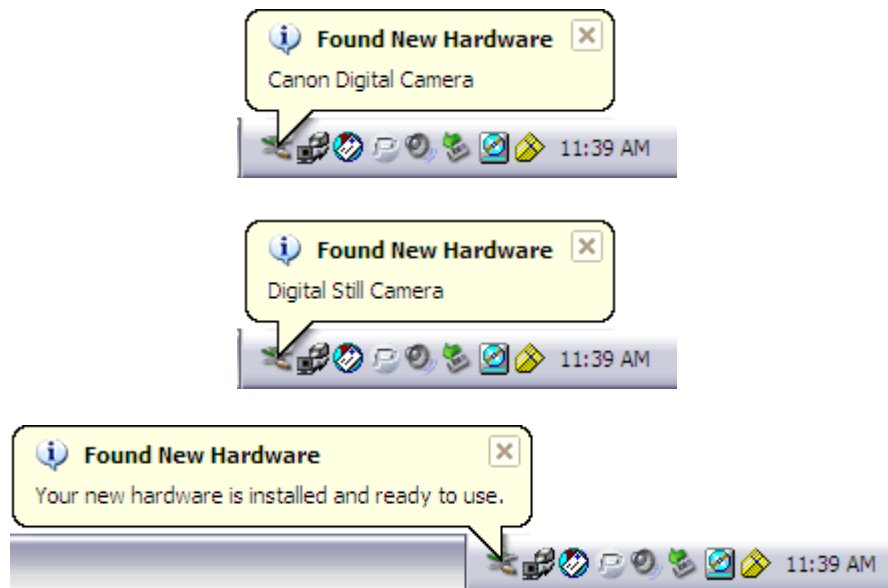

Center for Teaching and Learning

4. Double click on My Computer icon on the desktop. You will now be able to see the camera as a part of Cameras and Scanners attached to the computer.

Scanners and Cameras

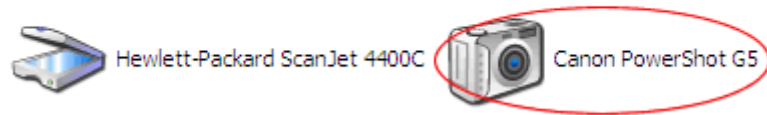

5. Double click on Canon PowerShot S400 icon. It will allow you to view the pictures you have taken.

6. Select the pictures that you like and want to download to the computer.

7. On the left side of the screen under File and Folder Tasks select Copy this item (if one photo selected) or Copy the selected items (if multiple photos selected).

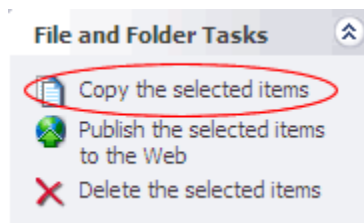

8. Choose a destination for your pictures and click Copy. It is recommended that you download the pictures in My Pictures folder under My Documents. The best way to do it is to create new folders (and don't forget to name the folder) for each event.

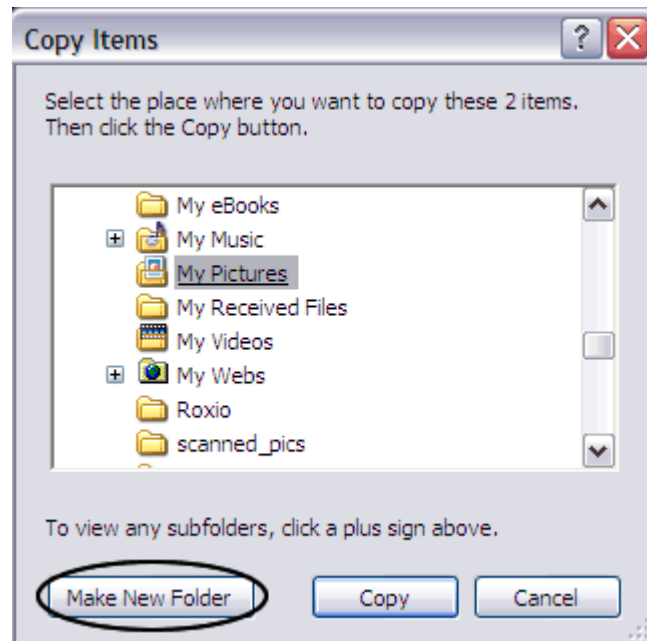

Center for Teaching and Learning

9. The computer will copy the images you have selected to the destination folder.

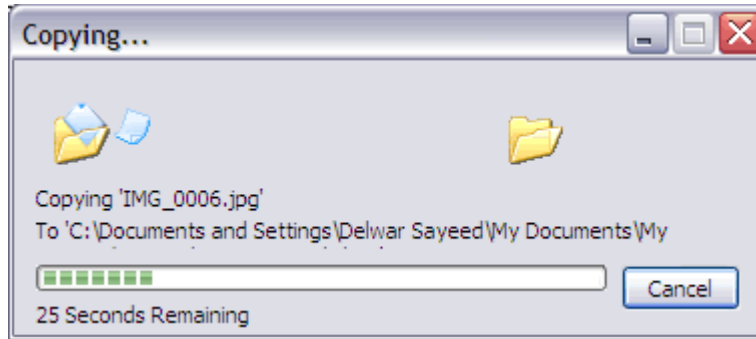

10. Open My Pictures (or the folder you chose) folder and any sub folders that you chose for your pictures. Your pictures will be there.

You are done! Hooray! 😊